

**Gleitlager-Scheiben**

Bestellbeispiel:  
WUS Innendurchmesser, Außendurchmesser, Stärke

**Slide washers**

Ordering example:  
WUS inside diameter, outside diameter, thickness

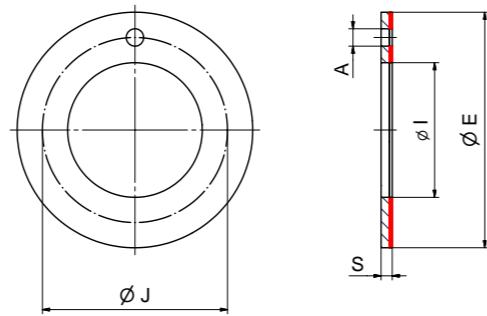

**Serie/Series WUS**

Abmessung/Dimensions mm					Gewicht/ Weight ≈ g
Ø I	Ø E	S	Ø J	A	
10	20	1,450 1,500	15	1,5	2,5
12	24		18	1,62 1,87	3,6
14	26		20		4,0
16	30		22	2,12 2,37	5,6
18	32		25		5,9
20	36		28		7,6
22	38		30	3,12 3,37	8,2
24	42		33		9,5
26	44		35	3,12 3,37	10,8
28	48		38		12,9
32	54	1,450 1,500	4		16,4
38	62		50		20,6
42	66		54	4,12 4,37	22,5
48	74		61		37,1
52	78	1,950 2,000	65		39,5
62	90		76		50,0



**Gleitlager-Streifen**

Bestellbeispiel:  
WUST Breite, Länge, Stärke

**Slide straps**

Ordering example:  
WUST width, length, thickness



**Serie/Series WUST**

Abmessung/Dimensions mm			Gewicht/ Weight ≈ g
S	B (± 2)	L (± 2)	
0,704 0,744	150	500	435
0,950 0,990	215	500	777
1,470 1,510	245	500	1.446
1,960 2,000	245	500	1.934
2,460 2,500	245	500	2.439
3,020 3,060	245	500	2.979



Allgemeine Toleranzen/ General tolerances

Nenninnen Ø I/inside Ø I | + 0,25 mm

Nennaußen Ø E/outside Ø E | - 0,25 mm

Teilkreisdurchmesser Ø J/ pitch circle Ø J | ± 0,12 mm

